

S4 Credit – Homework 5

Non-calculator section:

1. Express as a single fraction $\frac{\frac{1}{2} - \frac{1}{6}}{\frac{4}{9}}$

2. Solve the equation $\frac{x-1}{2} - \frac{2x}{3} = x$

3. The diagram opposite shows the graph of $y = a \sin bx$.

Write down the values of a and b .

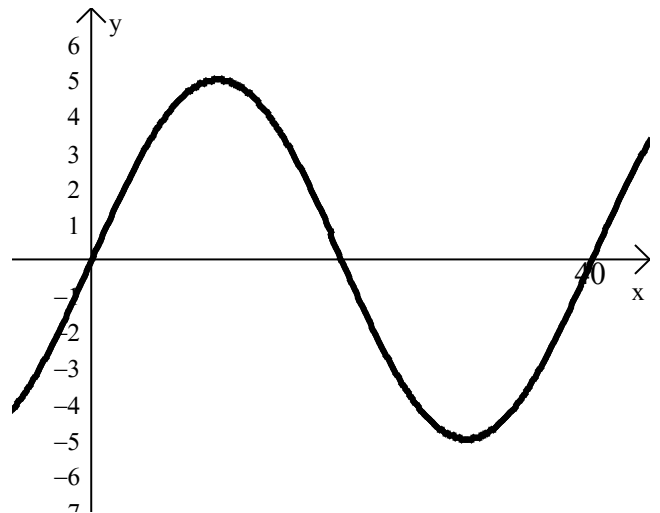

4. Given $\cos 60^\circ = \frac{1}{2}$, calculate x in the diagram opposite.

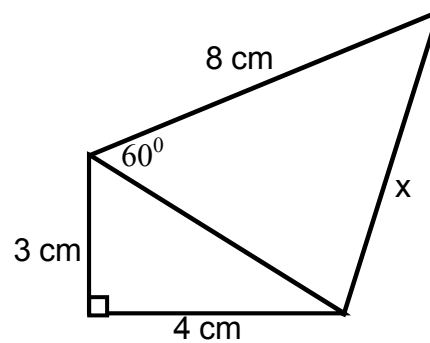

5. (a) Simplify $x^2(x^4 - \frac{3}{\sqrt{x}})$

(b) Evaluate $5^0 + 27^{\frac{2}{3}}$

6. Express $P = u - \frac{v}{w}$ in terms of w .

7. P varies directly as the cube of Q and inversely as R .
If Q is doubled and R is multiplied by 4, what will be the effect on P .

Calculator section:

8. Solve the equation $x^2 - x - 1 = 0$, giving your answers correct to 3 significant figures.

9. The prism shown has a cross-section in the shape of a regular hexagon of depth 5 cm.

The volume of the prism is 1871cm^3 .
Calculate x , to the nearest whole number.

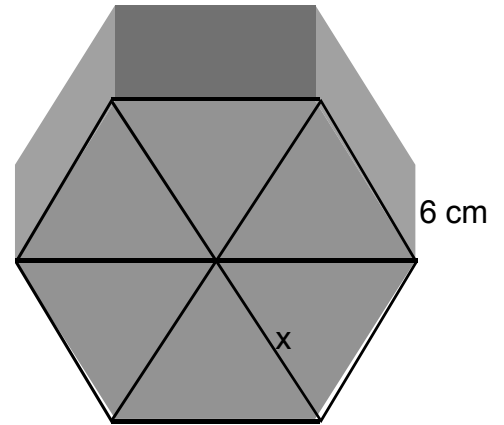

10. Show that $2\sqrt{6} - \frac{4}{\sqrt{6}}$ can be simplified to give $\frac{4\sqrt{6}}{3}$.

11. In mathematics one series of numbers is called triangular numbers.
Any number in the series can be found using the formula

$$T = \frac{n(n+1)}{2}$$

where T is the triangular number and n is its term in the series.

The triangular number 45 is which term in the series.

12. A delivery company promises next day delivery on all packages. The cost of delivery is £4.50 for packages weighing up to 10kg plus 30p for each extra kilogram above 10kg.

- (a) Find the cost of delivery for a package weighing 18kg.
(b) Write down a formula for the cost, £ C , of delivering a package weighing D kilograms, where $D > 10$.