

## Credit Mathematics – Homework B

### Non-calculator section:

1. Evaluate  $6.52 - 77.1 \div 30$
2. Expand the brackets and simplify  $(3a - 2)^2 - 2(1 - 6a)$

3. The scattergraph opposite shows the marks of a group of pupils in maths and physics exams. David scored 20 in maths and 27 in physics. Kulvir scored 90 in maths and 87 in physics.

- (a) Describe the relation between the maths and physics marks.
- (b) Find the equation of the line of best-fit.
- (c) John scored 63 in maths. Use your equation to estimate his physics mark.

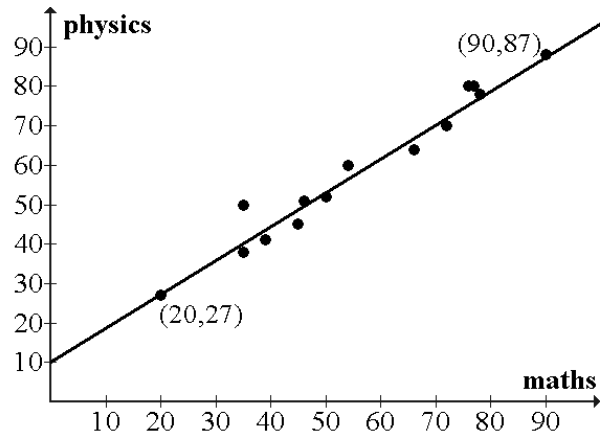

4. The prism opposite has a cross-section in the shape of a rectangle and a triangle. Given that the volume of this prism is  $48 \text{ m}^3$ , find the width of the prism.

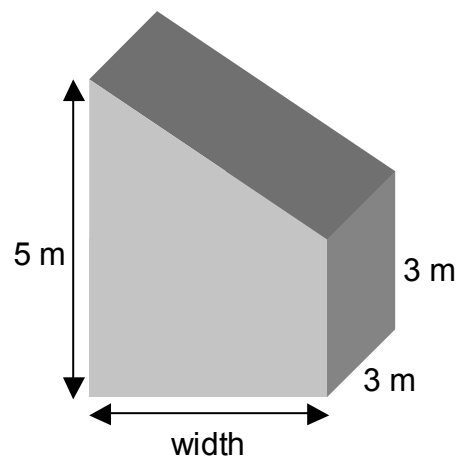

5. The diagram shows two lines with equations

$$3x - 2y = 10 \quad \text{and} \quad 4x + 3y = 19$$

Find the coordinates of P, the intersection of these lines.

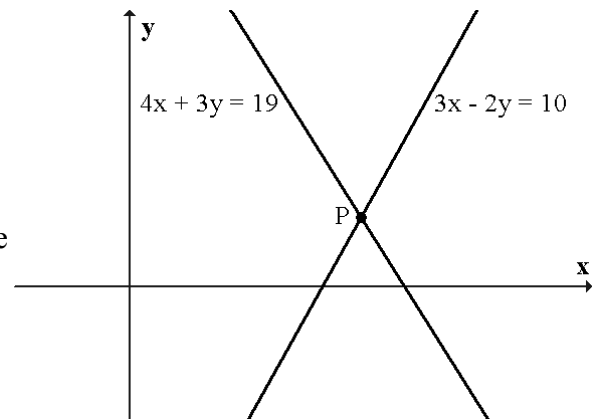

### Calculator section:

6. Solve the equation  $2x^2 - x = 9$ , giving your answer correct to 3 significant figures.

7. The roll of a Glasgow secondary school fell from 1100 in 2006 to 1045 in 2007.

- (a) Calculate the percentage fall in the roll between 2006 and 2007.
- (b) If the school roll continues to fall at this percentage rate, calculate the school roll in 2010.

8. Solve the equation  $3 \tan 45^\circ + 4 \cos x^\circ = 2$   $0^\circ \leq x^\circ \leq 360^\circ$

9. The diagram opposite shows a table consisting of an arc of a circle with a straight edge.

Calculate the perimeter of the table.

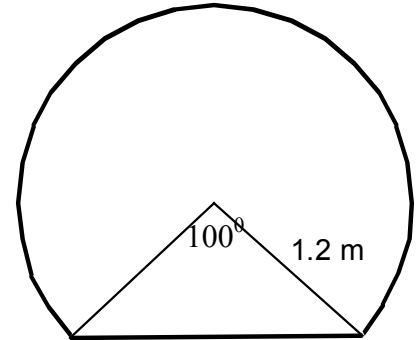

10. Express as a single fraction in its simplest form

$$\frac{6}{3x-1} - \frac{2}{x} \quad x \neq 0, \frac{1}{3}$$

11. The diagram shows the position of a ship and a lighthouse in a strait between two islands. Port B is directly east of port A at a distance of 12 kilometres. The lighthouse is directly north of the ship.

Calculate the distance,  $d$ , from the ship to the lighthouse

