

FOR OFFICIAL USE

| Presenting Centre No. | Subject No. | Level | Paper No. | Group No. | Marker's No. |
|-----------------------|-------------|-------|-----------|-----------|--------------|
|                       |             |       |           |           |              |

C

# perfectpapers

|             | KU | RE |
|-------------|----|----|
| Total Marks |    |    |
|             | 24 | 14 |

**[MATH(SG)06CP1]**

NATIONAL  
QUALIFICATIONS  
2006

Time: 55 minutes

MATHEMATICS  
STANDARD GRADE  
Credit Level  
Paper 1 (Non-Calculator)

Fill in these boxes and read what is printed below.

Full name of school or college

Town

First name and initials

Surname

Date of birth

Day    Month    Year

|  |  |  |  |  |  |
|--|--|--|--|--|--|
|  |  |  |  |  |  |
|--|--|--|--|--|--|

Read each question carefully.

You are **not** allowed to use a calculator in this paper.

Attempt **all** questions.

Write your answers in the space provided on the question paper.

Answer in sentences wherever possible.

Before leaving the examination room you must give this book to the invigilator. If you do not, you may lose all the marks for this paper.

*This test paper must be withdrawn from candidates after the examination and any follow-up discussion of marks/grades awarded. This is to ensure the 'sight unseen' status of this paper is maintained for your centre and other schools/colleges during the diet of prelim examinations in 2005/2006. Submission of this test paper for Appeals purposes will assume that these conditions have been applied.*

## FORUMULAE LIST

The roots of  $ax^2 + bx + c = 0$  are  $x = \frac{-b \pm \sqrt{b^2 - 4ac}}{2a}$

**Sine rule:**  $\frac{a}{\sin A} = \frac{b}{\sin B} = \frac{c}{\sin C}$

**Cosine rule:**  $a^2 = b^2 + c^2 - 2bc \cos A$  or  $\cos A = \frac{b^2 + c^2 - a^2}{2bc}$

**Area of a triangle:** Area =  $\frac{1}{2} ab \sin C$

| KU | RE |
|----|----|
| 2  |    |
| 2  |    |
| 2  |    |
| 3  |    |
| 1  |    |
| 2  |    |
|    | 4  |

1. Evaluate

$$27 \cdot 5 \div (2 \cdot 73 + 2 \cdot 27).$$

2. Evaluate

$$\frac{2}{5} \left( 2\frac{2}{3} + \frac{5}{6} \right)$$

3. Given that

$$f(x) = x^2 + 7x, \quad \text{evaluate } f(-2)$$

4. Solve algebraically the equation

$$\frac{1-4x}{3} + 3x = 4$$

5. (a) Factorise

$$9a^2 - 4b^2$$

(b) Hence simplify

$$\frac{6a-4b}{9a^2-4b^2}$$

6. A school recorded the number of detentions given in each month of the year.

| Month              | Aug | Sept | Oct | Nov | Dec | Jan | Feb | Mar | Apr | May | June |
|--------------------|-----|------|-----|-----|-----|-----|-----|-----|-----|-----|------|
| Number of visitors | 18  | 50   | 47  | 65  | 42  | 63  | 71  | 78  | 30  | 62  | 66   |

Find the median and quartiles ( $Q_1, Q_2$  &  $Q_3$ ) for the data and illustrate the information on a box plot.

[Turn Over

| KU | RE |
|----|----|
|    |    |
|    | 4  |
| 1  |    |
| 1  |    |
|    | 3  |

7. This scatter graph shows the relationship between the numbers of hours spent watching TV and the Maths exam mark of students in a class.

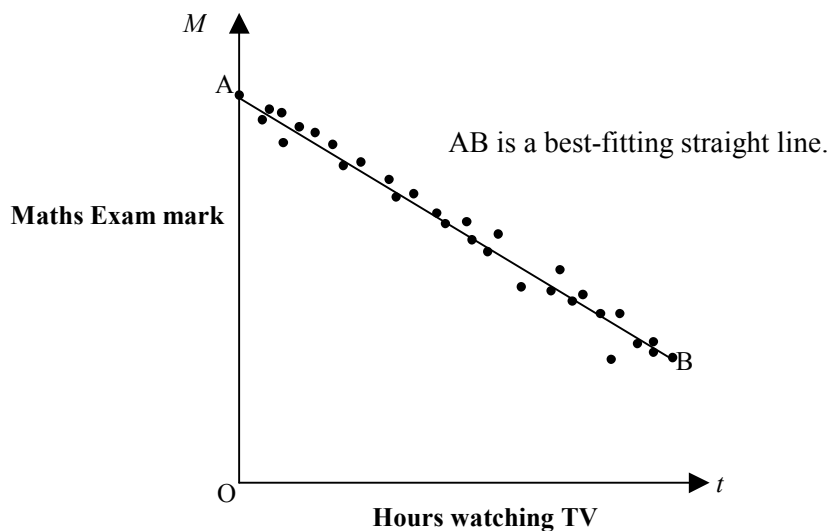

The student represented by point A watched 0 hours of TV and scored 93% in the exam.  
 The student represented by point B watched 50 hours of TV and scored 23% in the exam.

Find the equation of the straight line AB in terms of  $t$  and  $M$ .

8. Ross pays a monthly contract charge for his mobile phone.

**For this he gets 200 text messages and 200 minutes of calls.**

If he goes over this he incurs additional charges.

There is a charge per additional text message and a charge per additional minute of calls.

- (a) In one month he sends 4 additional text messages and makes 15 additional minutes of calls. His additional charges for the month are £1.23.

Let  $x$  be additional text messages and  $y$  be additional minutes of calls.  
 Write down an algebraic equation to illustrate his additional charges.

- (b) Rosie uses the same mobile phone company as Ross.

In the same month she sends 6 additional text messages and makes 17 additional minutes of calls.

Her additional charges are £1.57

Write down an algebraic equation to illustrate her additional charges.

- (c) Find the cost of one additional text message and one additional minute of calls.

| KU | RE |
|----|----|
| 1  | 2  |
| 4  |    |
| 2  |    |

9. The vase expert of an antiques programme keeps a record of the vases that are brought to him for valuation. The record of the first 400 vases is shown in the table below.

|      |             | Value (£) |         |           |          |
|------|-------------|-----------|---------|-----------|----------|
|      |             | 0 - 50    | 50 -100 | 100 - 500 | over 500 |
| Year | before 1950 | 10        | 10      | 70        | 90       |
| Made | after 1950  | 120       | 50      | 30        | 20       |

- (a) What is the probability that a vase chosen at random was made before 1950?
- (b) If the expert continues to keep his records until he has valued 2400 vases, how many would be expected to be worth more than £500 **and** made before 1950 ?

10.

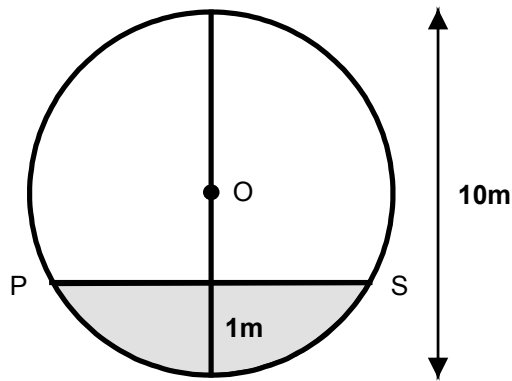

The cross-section of a cylindrical oil tank is shown above (not drawn to scale). The tank has a diameter of 10 metres and the depth of the oil is 1 metre.

Calculate the distance PS, the width of the oil surface.

11.

$$Q = \frac{1}{4}(P + T)$$

Change the subject of this formula to  $T$ .

[Turn Over

| KU | RE |
|----|----|
|    |    |
| 2  |    |
|    | 3  |
|    | 2  |

12. The graph of  $y = a \sin bx^\circ$  is shown below.

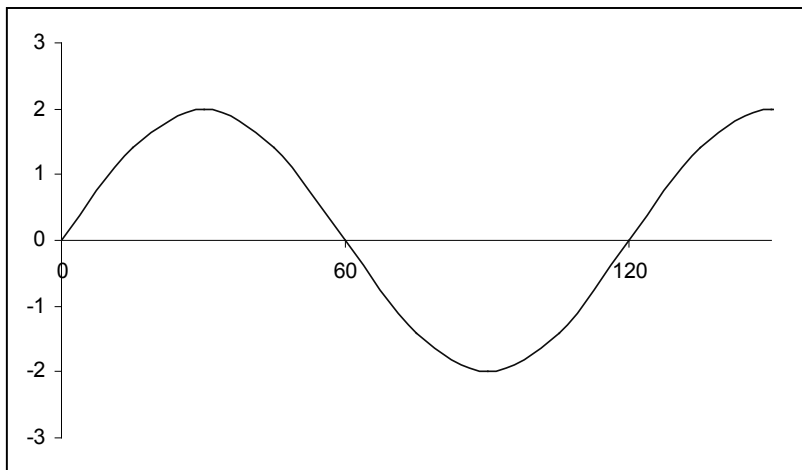

Write down the values of  $a$  and  $b$

13. A stone is thrown up into the air.  
The formula  $h = 20t - 5t^2$   
gives the height of the stone,  $h$ , in metres after  $t$  seconds.

(a) After how many seconds does the stone return to the ground?

(b) What is the maximum height reached by the stone?

**[END OF QUESTION PAPER]**

FOR OFFICIAL USE

| Presenting Centre No. | Subject No. | Level | Paper No. | Group No. | Marker's No. |
|-----------------------|-------------|-------|-----------|-----------|--------------|
|                       |             |       |           |           |              |

C

# perfectpapers

|             |    |    |
|-------------|----|----|
| Total Marks | KU | RE |
|             | 21 | 26 |

**[MATH(SG)06CP2]**

NATIONAL  
QUALIFICATIONS  
2006

Time: 1 hour 20 minutes

MATHEMATICS  
STANDARD GRADE  
Credit Level  
Paper 2

**Fill in these boxes and read what is printed below.**

Full name of school or college

Town

First name and initials

Surname

Date of birth

Day    Month    Year

|  |  |  |  |  |  |
|--|--|--|--|--|--|
|  |  |  |  |  |  |
|--|--|--|--|--|--|

Read each question carefully.

You are allowed to use a calculator in this paper.

Attempt **all** questions.

Write your answers in the answer book / paper provided.

Answer in sentences wherever possible.

Before leaving the examination room you must give this book to the invigilator. If you do not, you may lose all the marks for this paper.

*This test paper must be withdrawn from candidates after the examination and any follow-up discussion of marks/grades awarded. This is to ensure the 'sight unseen' status of this paper is maintained for your centre and other schools/colleges during the diet of prelim examinations in 2005/2006. Submission of this test paper for Appeals purposes will assume that these conditions have been applied.*

## FORUMULAE LIST

The roots of  $ax^2 + bx + c = 0$  are  $x = \frac{-b \pm \sqrt{(b^2 - 4ac)}}{2a}$

**Sine rule:**  $\frac{a}{\sin A} = \frac{b}{\sin B} = \frac{c}{\sin C}$

**Cosine rule:**  $a^2 = b^2 + c^2 - 2bc \cos A$  or  $\cos A = \frac{b^2 + c^2 - a^2}{2bc}$

**Area of a triangle:** Area =  $\frac{1}{2} ab \sin C$

| KU | RE |
|----|----|
|    |    |
| 3  |    |
| 2  |    |
| 4  |    |
|    | 4  |

1.

In February 2002 George bought a car for £9800.  
The car depreciates by 18% per year.



How much is the car worth in February 2005?

2.

A picture of a dust mite appears in a magazine.

The picture is 200 times actual size.

The actual length of this dust mite is  $3 \times 10^{-4}$  metres.

What is the length of the mite in the picture? **Give your answer in centimetres.**

3.

The diagram below shows part of an athletics field which is used for the shotput event.

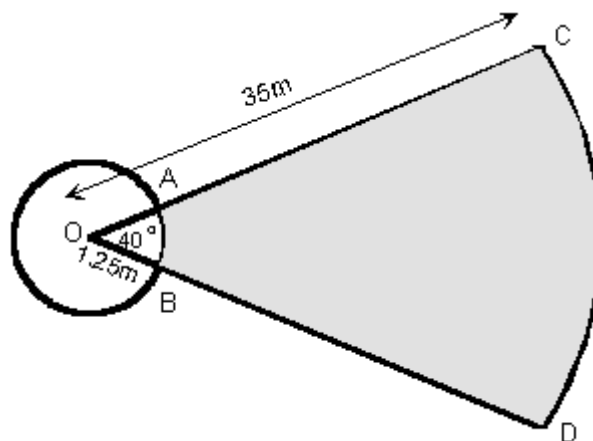

The shotput is thrown from within a circle of radius 1.25 metres and must land in the part of the field shaded. OAB and OCD are sectors of circles, centre O, with radii  $OB=1.25$  metres and  $OC=35$  metres. Angle  $AOB=40^\circ$ .

Calculate the area of the part of the field where the shotput must land to 2 decimal places.

4.

The diagram shows an earring.

$\angle DAB$  is  $127^\circ$

$AB = 14\text{mm}$ ,  $BC = 20\text{mm}$  and  $AC = 18\text{mm}$ .

Calculate the size of  $\angle DAC$ .

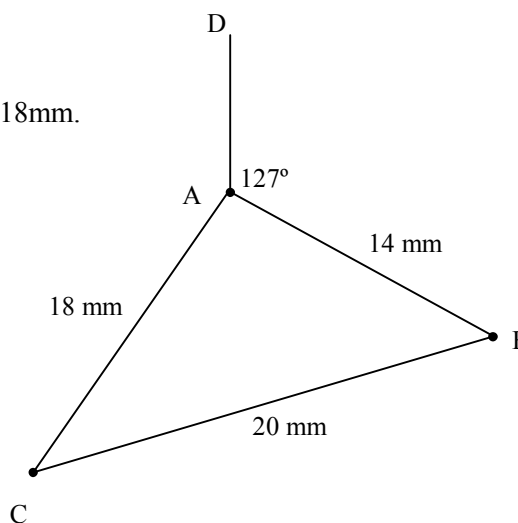

[Turn Over

5.

A cuboid and a cylinder have the same volume.  
 The cylinder is 14 cm tall and has a diameter of 7 cm.  
 The cuboid has a square base and has height of 11 cm.

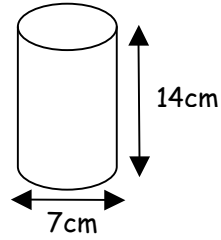

Calculate the length of side ( $x$ ) of the base of the cuboid.  
 Give your answer to **2 significant figures**.

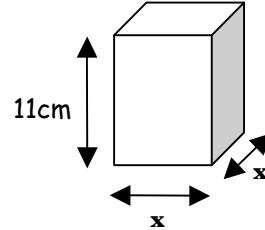

6. David uses the following rule when planning a hill walk.



**Time of walk** = 12 minutes for every kilometre walked + 1 minute for every 10 metres climbed.

(a) Write down a formula for working out the time of the walk ( $t$ ), given the distance walked ( $d$ ) and the height climbed ( $h$ ).

To raise money for the charity “Boots across Scotland”, David agrees to be at the top of a mountain at 2:00pm on Sunday afternoon.

(b) To be safe, David plans to be at the top 15 minutes early.  
 When should he begin his walk if the distance of the walk is 3.75 kilometres and the amount of climbing is 950 metres?

(c) Kenny arrives late at 12:36pm and has to run up the hill to be at the top by 2:00pm.  
 Calculate the speed he will need to run at (in kilometres per hour) and give your answer to 2 significant figures.

| KU | RE |
|----|----|
|    | 4  |
| 1  |    |
| 2  | 4  |

[Turn Over

7.

Work is about to commence on a 3 km stretch of motorway.  
 The stretch of motorway runs from East to West and is straight.  
 A rare bird's nest is found close to the motorway.  
 Bird experts say that the birds will not be disturbed provided that the motorway  
 is at least 1.5 km from the nest at its closest point.  
 From the West end of the stretch of motorway the nest is on a bearing of  $042^\circ$ .  
 From the East end it is on a bearing of  $323^\circ$ .

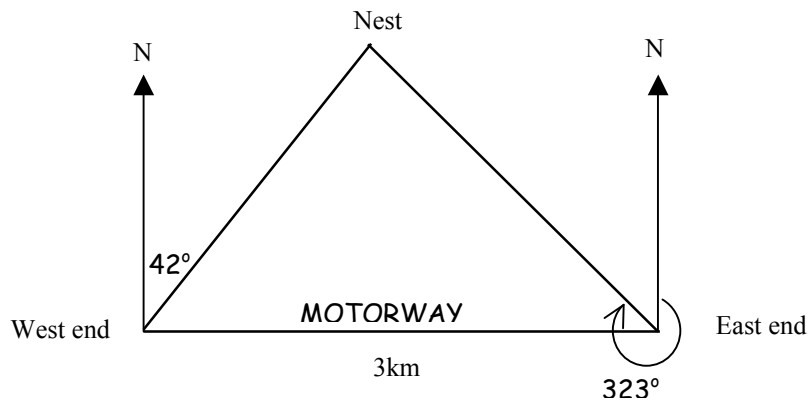

- (a) Calculate the distance from the nest to the East end of the motorway.  
 (b) Hence or otherwise, work out whether or not work can commence without disturbing the bird's nest.

8.

Find the two solutions to the equation

$$6 \sin x^\circ - 2 = 3 \quad 0 < x < 360$$

| KU | RE |
|----|----|
|    |    |
|    | 4  |
|    | 2  |
| 3  |    |

[Turn Over

| KU | RE |
|----|----|
|    |    |
| 4  |    |
| 3  |    |
|    | 3  |

9.

This picture shows a garden fence.

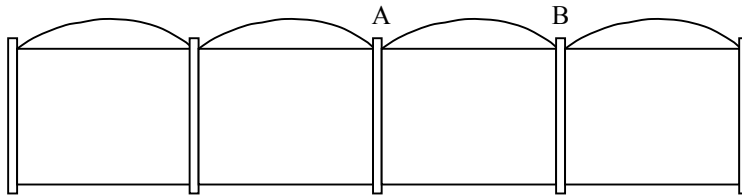

The curved part at the top of the fence panels is an arc of a circle as shown in the diagram below.

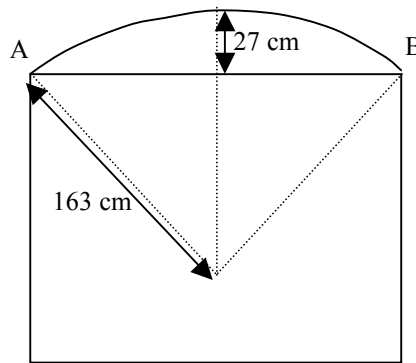

The radius of the arc is 163 cm and the curved part is 27 cm above the top of the fence panel at its highest point.

Calculate the width of the panel AB.

10.

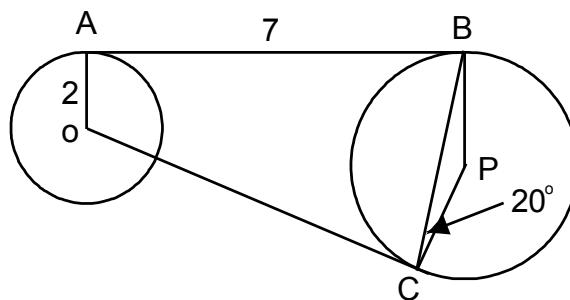

In the above diagram, AB is a tangent to both circles with centres at O and P. OC is a tangent line to the circle with centre P and angle BCP=20°.

- Find the size of angle AOC.
- The radius of the small circle is 2cm and the length of AB is 7cm. Calculate BP, the radius of the large circle.

