



C2

Fast Track

Knightswood
Secondary
School

MATHEMATICS
Standard Grade
Credit Level

Prelim Exam 2008

Paper 2 (calculator)

Time: 1 hour 20 minutes

Answer as many questions as you can.

In this paper good thinking is looked for as well as correct answers. Your working gives an indication of your thinking so **SHOW YOUR WORKING CLEARLY**.

You may use a calculator.

Square ruled paper is available.

Give all answers to 1 decimal place **unless otherwise stated**.

Formulae List

The roots of $ax^2 + bx + c = 0$ are $x = \frac{-b \pm \sqrt{b^2 - 4ac}}{2a}$

The Sine Rule: $\frac{a}{\sin A} = \frac{b}{\sin B} = \frac{c}{\sin C}$

Cosine Rule: $a^2 = b^2 + c^2 - 2bc \cos A$ or $\cos A = \frac{b^2 + c^2 - a^2}{2bc}$

Area of triangle: $A = \frac{1}{2}ab \sin C$

Trigonometric Relationships: $\frac{\sin x}{\cos x} = \tan x$, $\sin^2 x + \cos^2 x = 1$

Standard Deviation: $s = \sqrt{\frac{\sum(x - \bar{x})^2}{n - 1}} = \sqrt{\frac{\sum x^2 - \frac{(\sum x)^2}{n}}{n - 1}}$

1. A flash of lightning can cover the distance of 480 metres from cloud to ground in 0.000005 seconds.
Calculate the speed of the lightning flash in metres per second.
Give your answer in **scientific notation**.
2. Solve the equation $3x^2 - 5x - 7 = 0$
giving your answer correct to **2 significant figures**.
3. a) The students in a yoga class are being trained to control their breathing.
The length of time each member of the class holds their breath is recorded by the yoga teacher.
The times in seconds are;-
26 19 13 28 30 22 23
Find the **mean and standard deviation** for this data set.
b) An advanced yoga class has a mean of 35 seconds and a standard deviation of 3.5 seconds.
Make **two** valid comparisons between the classes.
4. Calculate the area of triangle LMN.

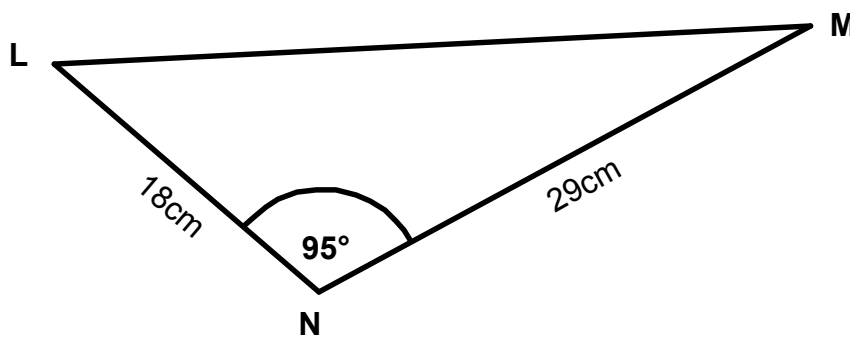

5. A fan-light window is in the shape of a semicircle of radius 76 centimetres.

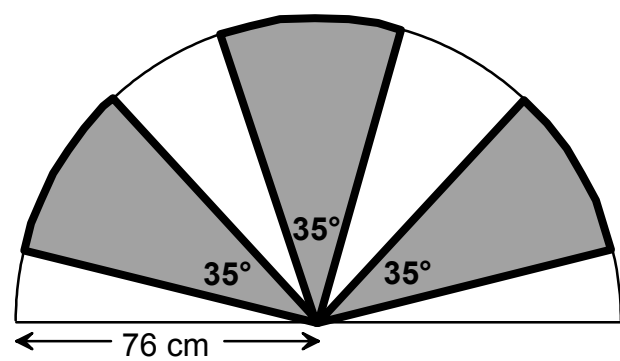

Set in the window frame are 3 identical panes of glass. Each pane of glass is a sector of a circle. The angle at the centre of each sector is 35° . Each pane of glass is edged with decorative copper wire, shown as a thick black outline.

Calculate the total length of wire needed for the edging.

KU	RE
3	
4	
4	
	2
3	
	4

6. The graph of $y = a \cos x + b$, $0 \leq x \leq 360^\circ$ is shown below.

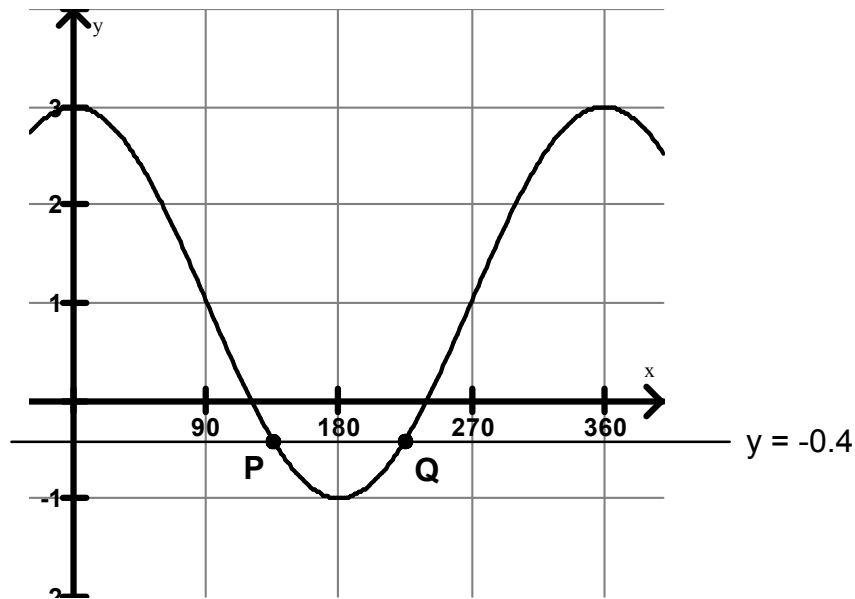

- a) Write down the values of **a** and **b**,
- b) The line $y = -0.4$ cuts the graph at P and Q.
Calculate the coordinates of P and Q.
7. If y varies inversely as the square root of x and $y = 8$ when $x = 9$,
calculate the value of y when $x = 64$.
8. A cone and a sphere have the **same volume**.
The cone has a radius of 7 centimetres and a height of 21 centimetres.

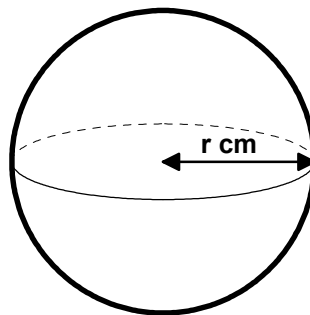
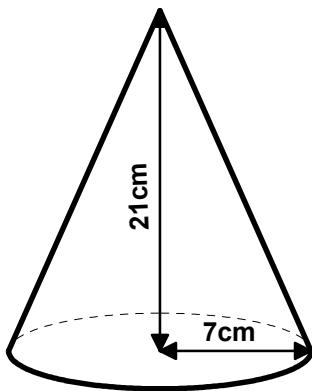

Volume of a cone: $V_{cone} = \frac{1}{3} \pi r^2 h$

Volume of a sphere: $V_{sphere} = \frac{4}{3} \pi r^3$

Calculate the radius of the sphere.

KU	RE
2	
	4
3	
	4

9. John and Bill are volunteers for mountain rescue. They are standing 760 metres apart at points A and B.

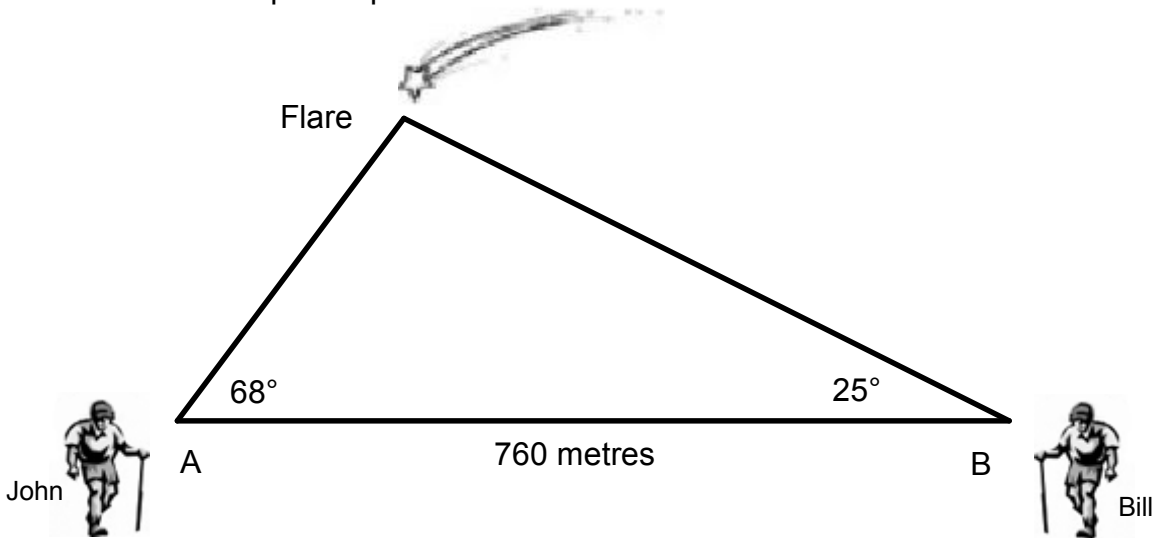

They spot a flare on a mountain. John measures the angle from AB to the flare as 68° . Bill measures the angle from AB to the flare as 25° . The diagram above illustrates this information.

Calculate the distance of John to the flare.

10. In the rectangle below, AB measures 12cm and AD measures 15cm.

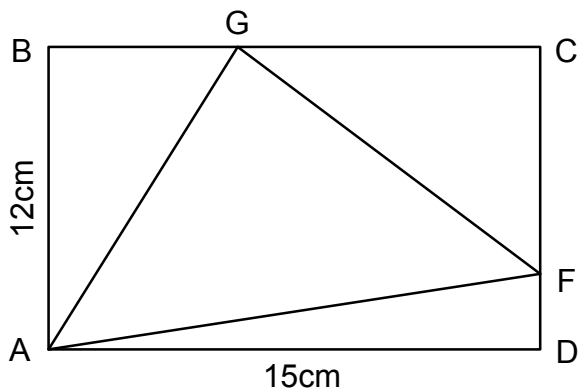

F divides DC in the ratio 1:3

G divides BC in the ratio 2:3

Calculate the area of triangle AFG.

11. Triangles ABC and DEF are similar and right angled at B and E.

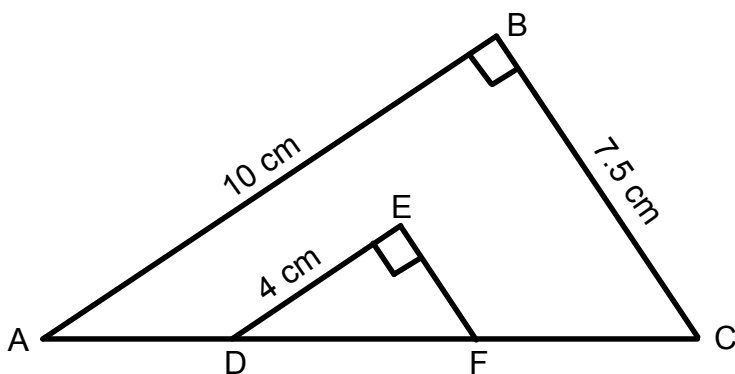

AB = 10 cm

BC = 7.5 cm

DE = 4 cm

- Calculate the length of EF.
- Hence calculate the length of DF.
- Hence calculate the length of AD + FC.

KU	RE
	4
	6
	2
	2
	3
25	25

[End of Question Paper]

No.	Give 1 mark per bullet point	Illustrations for awarding marks	KU	RE
1	Answer: 9.6×10^7 <ul style="list-style-type: none"> speed = distance/time solution solution in standard form 	<ul style="list-style-type: none"> $480 \div 0.000005$ 96 000 000 9.6×10^7 	3	
2	Answer: 2.6 and -0.91 <ul style="list-style-type: none"> values of coefficients substitution into formula process data solution correctly rounded 	using ax^2+bx+c <ul style="list-style-type: none"> $a=3, b=-5, c=-7$ $x = \frac{5 \pm \sqrt{25 - (4)(3)(-7)}}{6}$ $x=2.57... \text{ or } -0.9067...$ $x=2.6 \text{ or } -0.91$ 	4	
3a	Answer: $\bar{x} = 23 \quad s = 5.77$ <ul style="list-style-type: none"> mean $\sum x^2$ process data standard deviation 	<ul style="list-style-type: none"> $\bar{x} = 23$ $\sum x^2 = 3903$ $s = \sqrt{\frac{3903 - \frac{25921}{7}}{6}}$ $s = 5.77$ 	4	
3b	Answer: compare mean and standard deviation <ul style="list-style-type: none"> appropriate statement appropriate statement 	<ul style="list-style-type: none"> advanced class has higher mean less spread of data in higher class, more consistency 		2
4	Answer: 260 cm² <ul style="list-style-type: none"> use correct formula process data solution 	<ul style="list-style-type: none"> $A_{\Delta} = \frac{1}{2}ab \sin C$ $0.5 \times 18 \times 29 \times \sin 95$ 260 cm² 	3	
5	Answer: 595.3 cm <ul style="list-style-type: none"> ratio of arc to circumference length of arcs length of 6 radii solution 	<ul style="list-style-type: none"> $3 \times 35 \div 360$ $\frac{105}{360} \times 2 \times \pi \times 76$ add on 6×76 595.3 cm 		4
6a)	Answer: a=2 b=1 <ul style="list-style-type: none"> identify amplitude identify period 	<ul style="list-style-type: none"> 2 1 	2	
6b)	Answer: 134° and 226° <ul style="list-style-type: none"> from trigonometric equation solve for $\cos x^\circ$ solve for first solution solve for second solution 	<ul style="list-style-type: none"> $2 \cos x + 1 = -0.4$ $\cos x = -0.7$ 134° 226° 		4
7	Answer: 3 <ul style="list-style-type: none"> relationship of equation with k solve for k solve for y 	<ul style="list-style-type: none"> $y = \frac{k}{\sqrt{x}}$ $k = 24$ $y = 3$ 	3	

No.	Give 1 mark per bullet point	Illustrations for awarding marks	KU	RE
8	Answer: 6.4 cm <ul style="list-style-type: none"> • apply volume(cone) formula • use equal volumes • evidence of solving for r^3 • solve for radius of sphere 	<ul style="list-style-type: none"> • $\frac{1}{3}\pi \times 7^2 \times 21 = 1077.56$ • $\frac{4}{3}\pi \times r^3 = 1077.56$ • $r^3 = 257.25$ • $r = 6.4 \text{ cm}$ 	4	
9	Answer: 322 m <ul style="list-style-type: none"> • find angle AFB • apply Sine Rule • process data • solution 	<ul style="list-style-type: none"> • $180 - 93 = 87^\circ$ • $\frac{b}{\sin 25} = \frac{760}{\sin 87}$ • $b = \frac{760 \times \sin 25}{\sin 87}$ • $b = 322$ 		4
10	Answer: 81 <ul style="list-style-type: none"> • use ratio to find DF, FC • use ratio to find BG, GC • use area of triangle formula • find areas of $\triangle ADF, \triangle ABG, \triangle GFC$ • find area of rectangle • area of $\triangle AFG$ 	<ul style="list-style-type: none"> • DF = 3, FC = 9 • BG = 6, GC = 9 • $Area_{\triangle} = \frac{1}{2}bh$ • $22\frac{1}{2}, 36, 40\frac{1}{2}$ • $12 \times 15 = 180$ • $180 - 99 = 81$ 		6
11a)	Answer: 3 cm <ul style="list-style-type: none"> • apply ratio to side EF • solution 	<ul style="list-style-type: none"> • 4:10 • $4 \div 10 \times 7.5 = 3$ 	2	
11b)	Answer: 5 <ul style="list-style-type: none"> • know to use Pythagoras • apply Pythagoras correctly 	<ul style="list-style-type: none"> • 3, 4, 5 Pythagorean triple • DF = 5 <p><i>note: candidates who don't know that similar triangles are equiangular will find AC by Pythagoras (12.5) and then scale to find DF.</i></p>		2
11c)	Answer: 7.5 cm <ul style="list-style-type: none"> • Apply Pythagoras • length of AC • length of AD+FC 	<ul style="list-style-type: none"> • $AC = \sqrt{10^2 + 7.5^2}$ • AC = 12.5 • $AD + FC = 12.5 - 5 = 7.5$ 		3
		Total	25	25