

Prelim Examination 2007 / 08

MATHEMATICS
National Qualifications - Intermediate 2
Maths 1 and 2
Paper 1 (non-calculator)

Time allowed - 45 minutes

Read carefully

1. You may **NOT** use a calculator.
2. Full credit will be given only where the solution contains appropriate working.
3. Square-ruled paper is provided.

FORMULAE LIST

Sine rule:
$$\frac{a}{\sin A} = \frac{b}{\sin B} = \frac{c}{\sin C}$$

Cosine rule:
$$a^2 = b^2 + c^2 - 2bc \cos A \text{ or } \cos A = \frac{b^2 + c^2 - a^2}{2bc}$$

Area of a triangle:
$$\text{Area} = \frac{1}{2} ab \sin C$$

Volume of a sphere:
$$\text{Volume} = \frac{4}{3} \pi r^3$$

Volume of a cone:
$$\text{Volume} = \frac{1}{3} \pi r^2 h$$

Volume of a cylinder:
$$\text{Volume} = \pi r^2 h$$

Standard deviation:
$$s = \sqrt{\frac{\sum (x - \bar{x})^2}{n - 1}} = \sqrt{\frac{\sum x^2 - (\sum x)^2 / n}{n - 1}}$$
, where n is the sample size.

All questions should be attempted

Marks

1. The table below shows the number of goals scored by each team in a football tournament.

Number of goals	Number of teams	Cumulative frequency
0	20	
1	24	
2	9	
3	7	

- (a) Copy the table and complete the cumulative frequency column. [1]
- (b) What is the probability that a team chosen at random will have scored more than one goal in a game? Give your answer in its simplest form. [2]
- (c) Construct a pie chart on the worksheet provided to illustrate the data. [3]

2. (a) Establish the equation of the straight line shown in the diagram. [3]

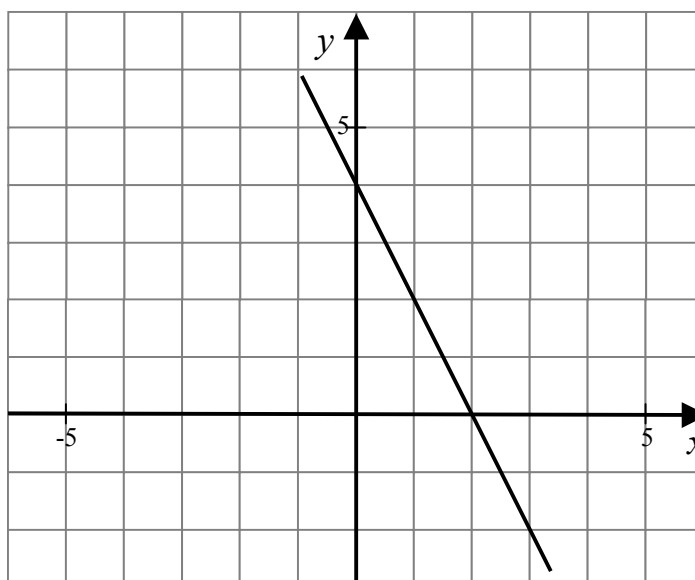

- (b) A copy of the diagram can be found on the worksheet. On this diagram sketch the line with equation $y = \frac{1}{2}x - 1$ and write down the point of intersection of the two lines. [4]

3. Multiply out the brackets and simplify

$$(x - 2)(x^2 + 6x - 5)$$

[3]

4. In a supermarket the manager noted the times, in minutes, that a sample of customers spent in the store first thing in the morning.

The results are shown in the stem and leaf diagram below

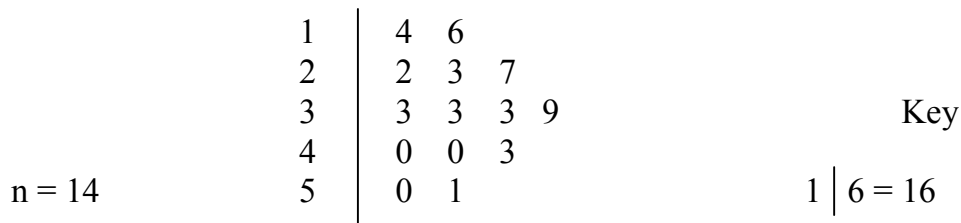

(a) For the given data, find the median, the lower quartile and the upper quartile. [3]

(b) Construct a box-plot for the data on the worksheet provided. [2]

5. The diagram shows a square piece of card with side $(3x + 1)$ cm.

A square of side 4cm is cut out of it.

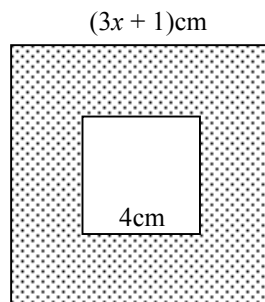

(a) Show clearly that the area of card can be expressed as

$$9x^2 + 6x - 15$$

[3]

(b) Factorise the above expression fully.

[2]

6. The marks of a group of students in a class test (C) and in the final exam (F) are shown in the scattergraph below.
The **line of best fit** has been drawn.

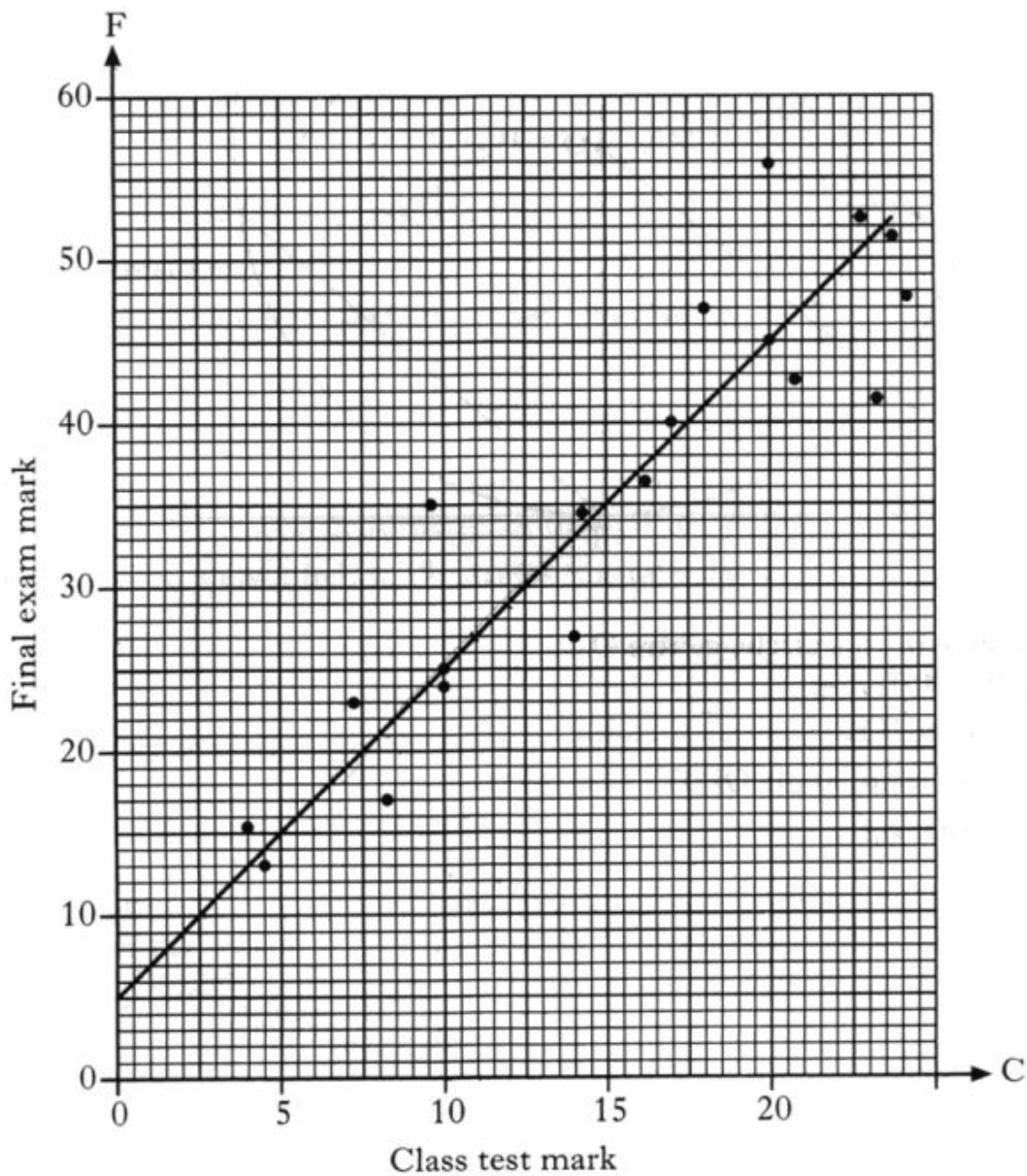

- (a) Find the equation of best fit. [3]
- (b) Use your answer to part (a) to predict the final exam mark for a student who achieved a mark of 12 in the class test. [1]

END OF QUESTION PAPER

Worksheet to accompany Intermediate 2 Prelim Units 1 and 2 Paper 1 2007/2008

Name: _____

Question 1 (c)

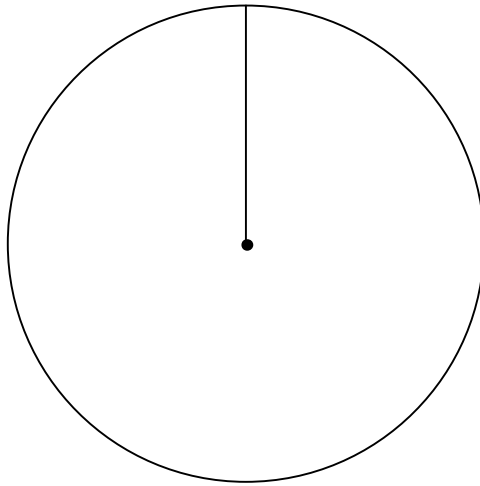

Question 2(b)

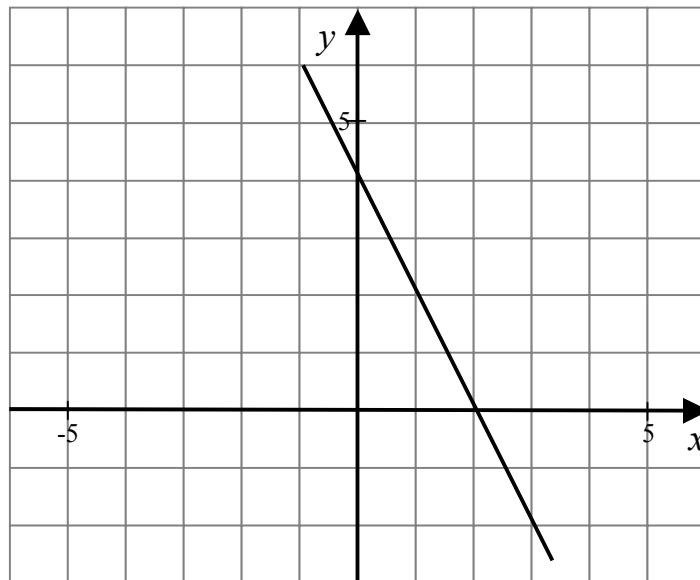

Question 4(b)

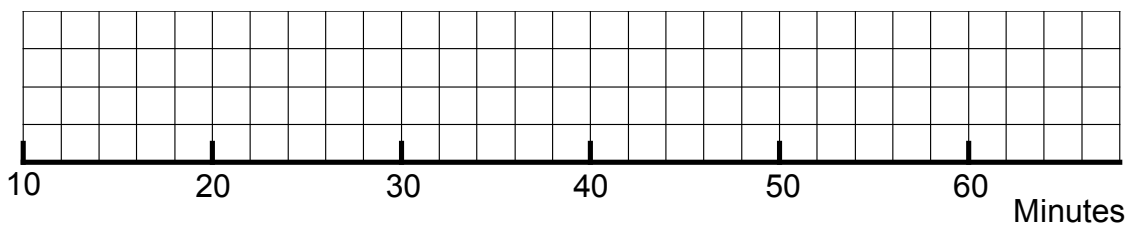

Qu	Give one mark for each •	Illustration for awarding mark
1a	ans: 20, 44, 53, 60 1 mark • ¹ correct cumulative frequencies	• ¹ 20, 44, 53, 60
b	ans : $\frac{4}{15}$ 2 marks • ¹ correct probability • ² simplifies fraction	• ¹ 16/60 • ² 4/15
c	ans: pie chart drawn 3 marks • ¹ knows how to calculate angles • ² draws pie chart • ³ labels sectors	• ¹ $20/360 \times 360 = 120^\circ, 144^\circ, 54^\circ, 42^\circ$ • ² worksheet • ³ worksheet
2a	ans : $y = -2x + 4$ 3 marks • ¹ finds gradient of the line • ² finds y - intercept • ³ states equation of line	• ¹ $m = -2$ • ² $y - \text{intercept} = 4$ • ³ $y = -2x + 4$
b	ans: (2,0) 4 marks • ¹ correct y – intercept point on graph • ² correct x – intercept point on graph • ³ draws line • ⁴ reads off point of intersection	• ¹ (0,-1) • ² (2, 0) • ³ worksheet • ⁴ (2,0)
3	ans : $x^3 + 4x^2 - 17x + 10$ 3 marks • ¹ starts to multiply brackets • ² completes multiplication • ³ simplifies to answer	• ¹ $x^3 + 6x^2 - 5x \dots\dots\dots$ • ² $\dots\dots\dots - 2x^2 - 12x + 10$ • ³ $x^3 + 4x^2 - 17x + 10$
4a	ans : 33; 23; 40 3 marks • ¹ finds median • ² finds lower quartile • ³ finds upper quartile	• ¹ $Q_2 = 33$ • ² $Q_1 = 23$ • ³ $Q_3 = 40$
b	ans: box-plot drawn 2 marks • ¹ correct box • ² correct whiskers	• ¹ see below • ² see below

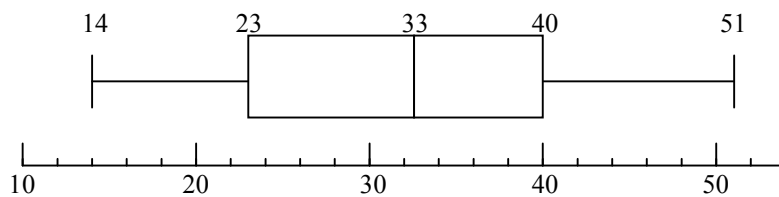

Qu	Give one mark for each •	Illustration for awarding mark
5a	ans : proof 3 marks <ul style="list-style-type: none"> •¹ strategy: one area – other •² finds expression for area •³ multiplies brackets and simplifies 	<ul style="list-style-type: none"> •¹ evidence of one area – other area •² $(3x+1)^2 - 16$ •³ $9x^2 + 6x + 1 - 16 = 9x^2 + 6x - 15$
b	ans: proof 2 marks <ul style="list-style-type: none"> •¹ identifies common factor •² factorises expression 	<ul style="list-style-type: none"> •¹ $3(\dots\dots)(\dots\dots)$ •² $\dots(3x + 5)(x - 1)$
6	ans : F = 2C+5, 29 4 marks <ul style="list-style-type: none"> •¹ Identifies intercept •² Finds gradient •³ Establishes equation •⁴ Substitutes and calculates correctly 	<ul style="list-style-type: none"> •¹ $c = 5$ •² $m = 2$ •³ $F = 2C + 5$ •⁴ $F = 2(12) + 5 = 29$
		Total 30 marks

Prelim Examination 2007 / 08

<p>MATHEMATICS National Qualifications - Intermediate 2 Maths 1 and 2 Paper 2</p>

Time allowed - 1 hour 30 minutes

Read carefully

- 1. Calculators may be used in this paper.**
- 2. Full credit will be given only where the solution contains appropriate working.**
- 3. Square-ruled paper is provided.**

FORMULAE LIST

Sine rule:
$$\frac{a}{\sin A} = \frac{b}{\sin B} = \frac{c}{\sin C}$$

Cosine rule:
$$a^2 = b^2 + c^2 - 2bc \cos A \text{ or } \cos A = \frac{b^2 + c^2 - a^2}{2bc}$$

Area of a triangle:
$$\text{Area} = \frac{1}{2} ab \sin C$$

Volume of a sphere:
$$\text{Volume} = \frac{4}{3} \pi r^3$$

Volume of a cone:
$$\text{Volume} = \frac{1}{3} \pi r^2 h$$

Volume of a cylinder:
$$\text{Volume} = \pi r^2 h$$

Standard deviation:
$$s = \sqrt{\frac{\sum (x - \bar{x})^2}{n - 1}} = \sqrt{\frac{\sum x^2 - (\sum x)^2 / n}{n - 1}}$$
, where n is the sample size.

1. A piece of jewelry was bought for £2580 two years ago. Its present value is 65% of its original price.
- (a) What is its present day value? [2]
- An expert estimates that it will increase in value at a rate of 12% per annum over the next few years.
- (b) How many years will it take for the jewelry to regain its original value? [3]
2. Jason goes to the local leisure centre. He books 1 hour of tennis and 3 hours of swimming. The total cost is £13.25
- (a) If 'x' is the cost of an hour of tennis and 'y' the cost of an hour of swimming, write an equation for the cost of Jason's visit. [1]
- Janet visits the same leisure centre. She books 2 hours of tennis and 4 hours of swimming and pays £22.50
- (b) Write another equation for the cost of Janet's visit. [1]
- (c) Sunni visits the leisure centre and books 1 hour of tennis and 1 hour of swimming. How much did he pay in total? (Show all your working) [4]
3. The pulse rate was taken for 6 adults after a theatre show. They were,
- 68 73 86 72 82 78 beats per minute
- (a) Calculate the **mean** and **standard deviation** for this data set. [4]
- 6 children were also tested after the show. They had a mean pulse rate of 89.6 beats per minute and had a standard deviation of 5.4.
- (b) Make **two** valid comparisons between the children's pulse rates and those of the adults. [2]

4. A hemispherical bowl has diameter 30cm.

- (a) Calculate the volume of the bowl giving your answer correct to 3 significant figures.

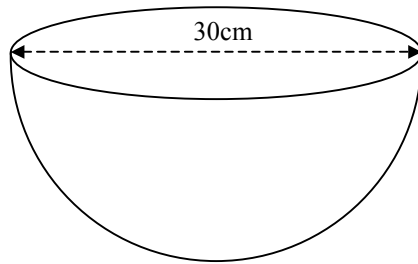

[4]

- (b) For a birthday party the bowl is completely filled with fruit punch and then transferred into cone shaped glasses like the one shown in the diagram below.

The depth of the liquid in each glass is 7cm and 50 glasses can be filled from the liquid in the bowl.

Calculate the radius, r , of the liquid's surface.

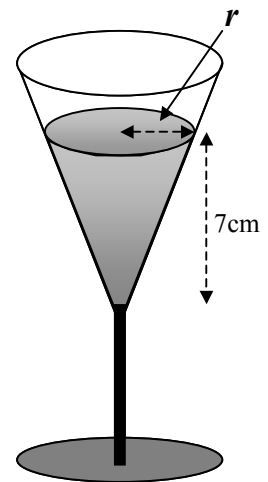

[4]

5. The entrance to a tunnel is shown below. It is circular with chord PG as shown.

The diagram below shows it's cross-section.

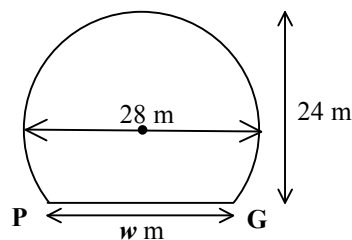

Given that the diameter of the circle is 28 m and its height is 24 m, calculate the width, w m, of it.

[4]

6. A piece of ground is in the shape of a quadrilateral ABCD as shown below.

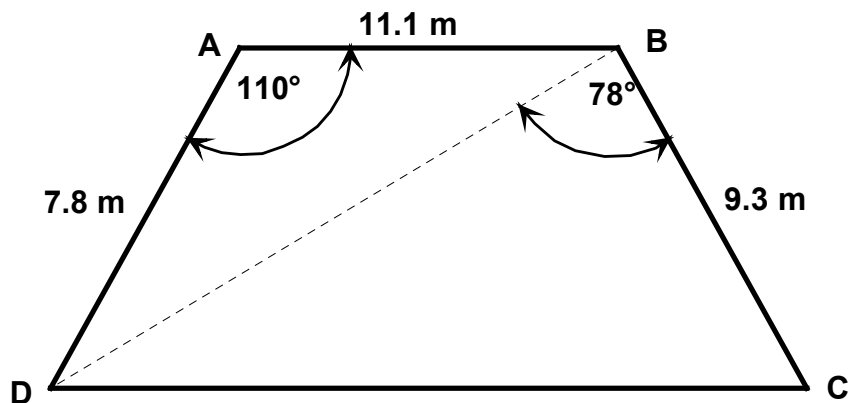

(a) Calculate the length of **BD**
(Do not use a scale drawing) [3]

(b) Find the area of the whole piece of ground. [4]

7. A stall at a summer bazaar is trimmed with this design.

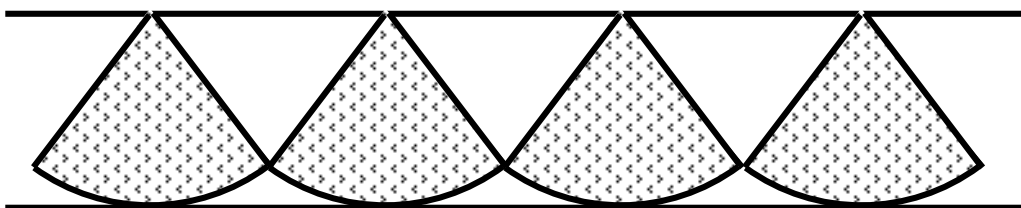

Each 'section' is a sector of a circle with radius 15cm as shown in the diagram below.

At its widest point, each section is 20cm.

(a) Use the **cosine rule** to calculate (to the nearest degree) the size of angle ABC.

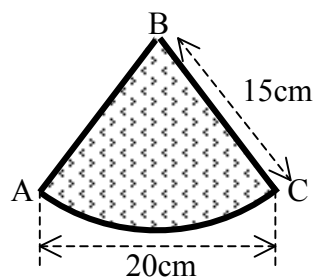

[3]

(b) Hence calculate the total area of 10 such sections. [3]

END OF QUESTION PAPER

Qu	Give one mark for each •	Illustrations for awarding mark
1a	ans: £1 677 2 marks	<ul style="list-style-type: none"> •¹ 0.65 × 2 580 •² £1 677
	<ul style="list-style-type: none"> •¹ correct multiplier •² answer 	
b	ans: 4 years 3 marks	<ul style="list-style-type: none"> •¹ × 1.12 •² evidence of repeated calculation •³ 4 years
	<ul style="list-style-type: none"> •¹ uses correct multiplier •² repeats calculation •³ answer 	
2a	ans : $x + 3y = 13.25$ 1 mark	<ul style="list-style-type: none"> •¹ $x + 3y = 13.25$
b	ans: $2x + 4y = 22.50$ 1 mark	<ul style="list-style-type: none"> •¹ $2x + 4y = 22.50$
	<ul style="list-style-type: none"> •¹ correct equation 	
c	ans : £13.50 4 marks	<ul style="list-style-type: none"> •¹ evidence •² $x + 3y = 13.25$; $2x + 6y = 26.50$ •³ $x = 7.25$; $y = 2$ •⁴ $£7.25 + £2 + £4.25 = £13.50$
	<ul style="list-style-type: none"> •¹ knows to solve system of equations •² prepares equations to solve •³ finds value of x and y •⁴ communicates answer 	
3a	ans: mean = 76.5; S.D. = 6.7 4 marks	<ul style="list-style-type: none"> •¹ $459/6 = 76.5$ •² 210681, 35341 •³ $\sqrt{\frac{35341 - (\frac{210681}{6})}{5}}$ •⁴ 6.7
	<ul style="list-style-type: none"> •¹ finds mean •² finds $(\sum x)^2$ and $\sum x^2$ •³ substitutes into formula •⁴ finds Standard Deviation 	
b	ans: comparison 2 marks	<ul style="list-style-type: none"> •¹ higher mean so higher pulse rate •² smaller SD so pulse is more consistent than before
	<ul style="list-style-type: none"> •¹ compares mean •² compares SD 	
4a	ans: $7\,070\text{cm}^3$ 4 marks	<ul style="list-style-type: none"> •¹ $v = 2/3 \times \pi \times 15^3$ •² $r = 15$ (could be in formula) •³ $7\,068.58\dots\text{cm}^3$ (7065 with 3.14) •⁴ $7\,070\text{cm}^3$
	<ul style="list-style-type: none"> •¹ uses appropriate formula •² uses correct radius •³ answer •⁴ rounds correctly 	
b	ans: 4.4cm 4 marks	<ul style="list-style-type: none"> •¹ $7070 \div 50 = 141.4\text{cm}^3$ •² $141.4 = 1/3 \times \pi \times r^2 \times 7$ •³ $r^2 = 424.2/7 \pi$ •⁴ $r = \sqrt{424.2/(7\pi)} = 4.4\text{cm}$
	<ul style="list-style-type: none"> •¹ finds volume of 1 glass •² substitutes into formula •³ rearranges to r^2 •⁴ finds r 	

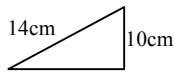
Qu	Give one mark for each •	Illustrations for awarding mark
5	ans: 19.6 m 4 marks <ul style="list-style-type: none"> •¹ assembles facts in right-angled triangle •² knows to use Pythagoras' •³ calculates half width •⁴ finds width 	 <ul style="list-style-type: none"> •¹ •² $14^2 - 10^2$ •³ $\sqrt{(96)} = 9.8\text{m}$ •⁴ $9.8 \times 2 = 19.6\text{m}$
6a	ans : 15.6 m 3 marks <ul style="list-style-type: none"> •¹ uses correct formula •² uses $\cos 110^\circ$ •³ finds square root 	<ul style="list-style-type: none"> •¹ $a^2 = b^2 + c^2 - 2bccosA$ •² -0.342 •³ calculates 15.6
b	ans: 111.5 m² 4 marks <ul style="list-style-type: none"> •¹ uses correct formula •² evaluates •³ uses correct formula •⁴ evaluates and adds 	<ul style="list-style-type: none"> •¹ Area = $\frac{1}{2} bdsinA$ •² 40.6 m² •³ Area = $\frac{1}{2} cdsinB$ •⁴ 70.9 + 40.6
7a	ans: 84° 3 marks <ul style="list-style-type: none"> •¹ substitutes appropriate value into rule •² finds angle •³ rounds correctly 	<ul style="list-style-type: none"> •¹ $\frac{15^2 + 15^2 - 20^2}{2 \times 15 \times 15}$ •² 83.6° •³ 84°
b	ans: 1649cm² 3 marks <ul style="list-style-type: none"> •¹ correct fraction •² finds area of 1 section •³ finds area of 10 sections 	<ul style="list-style-type: none"> •¹ 84/360..... •² $\pi \times 15^2 = 164.9\text{cm}^2$ •³ $164.9 \times 10 = 1649\text{cm}^2$
		Total 42 marks